

CAD FILE:

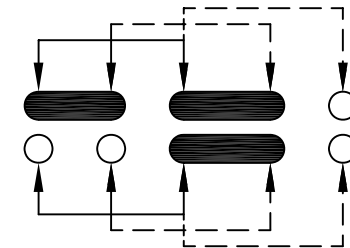

SCHEMATIC (SHORTING)

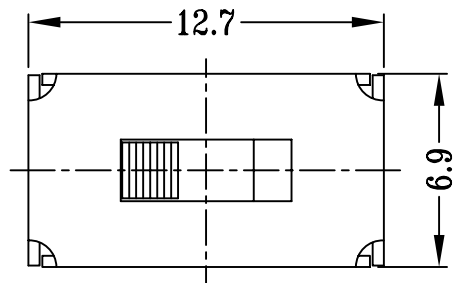
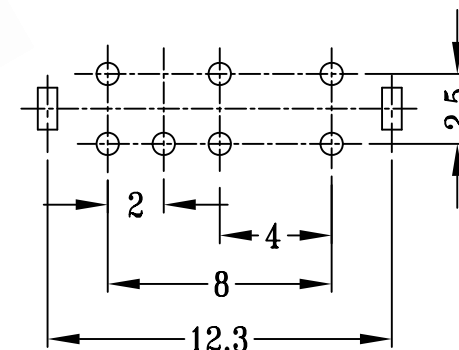
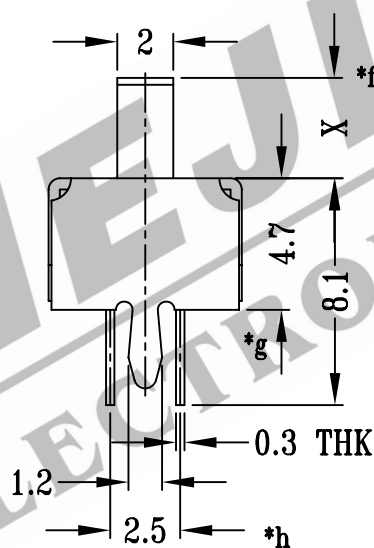
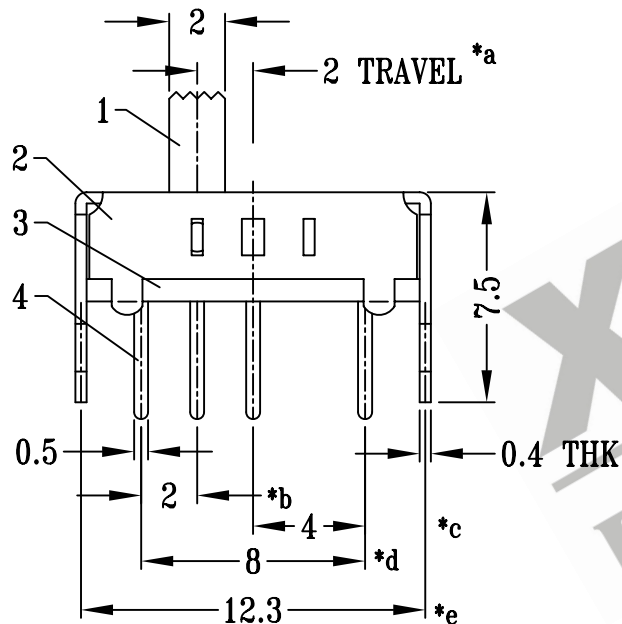

P.C.B LAYOUT

注:带"\*"表示关键尺寸(8个)

					TOLERANCE UNLESS SPECIFIED		SHENZHEN XIEJIA ELECTRONICS CO.,LTD.				
					WITHIN: 1.5±0.1mm OVER : 1.5±0.2mm		ISSUE	DATE	DESCRIPTIONS OF REVISION		APPD.
8											
7											
6	SPRING PLATE	STAINLESS STEEL	2	NATURAL	TITLE : VERTICAL SLIDE SWITCH			UNIT : mm		DRWG NO.: XJ-DR-SS23D08-00	
5	CONTACT CLIP	PBS	2	Ag CLAD				SCALE: 7 : 2		DWN.	ZHOUYU
4	TERMINAL	BRASS STRIP	7	Ag PLATED OVER Ni PLATED	MODEL: SS-23D08			CHK'D	FANGYING	2004-4-9	
3	BASE	PHENOLIC RESIN	1	NATURAL				ALL MATERIALS MUST BE COMPLIANT TO ROHS		APPD.	KANGXINAN
2	FRAME	STEEL STRIP	1	Ni PLATED							
1	KNOB	POM	1	BLACK							
NO.	PARTS	MATERIALS	Q'TY	FINISH							